

AdvancedTCA™

A major new spec for a narrower
market

And this is a good thing?

AdvancedTCA™



The platform spec dilemma

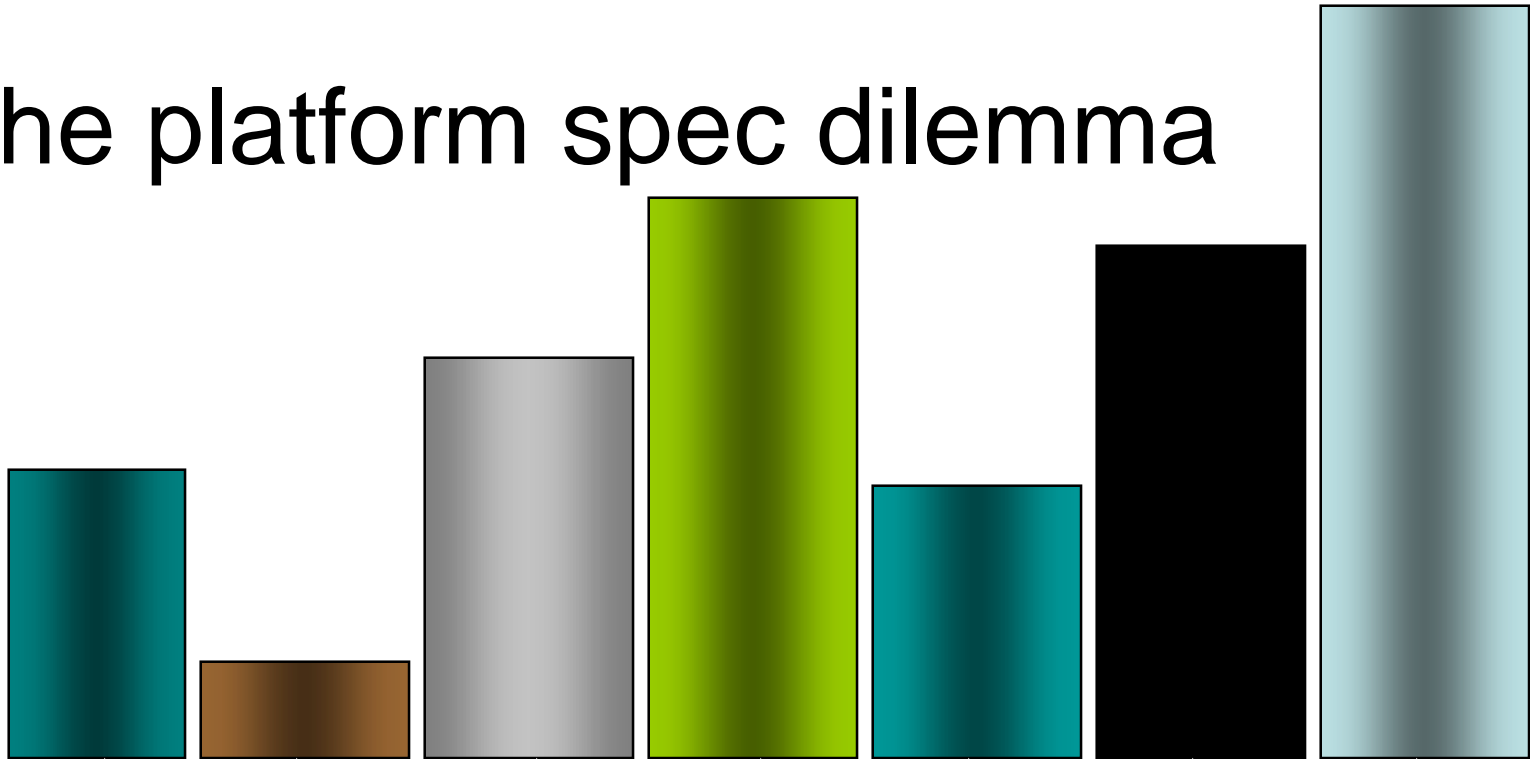

Vertical Market Needs

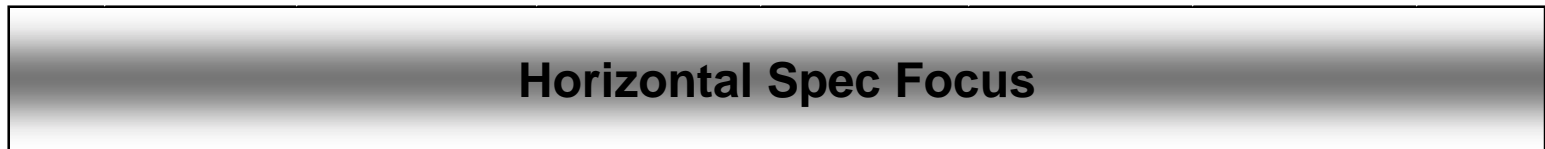

AdvancedTCA™



CompactPCI is horizontally focused

- Core Spec is General
- Higher level functions are open
- No one target industry
- Added features and industry focus left to later spec numbers
 - Hot Swap – 2.1
 - System Management 2.9
 - Telco Data plane – 2.5
 - Instrumentation extensions 2.8
- Makes for a broadly applicable spec for many industries
- Still very useful

AdvancedTCA™



Flexibility vs Exact Fit

Closed

<p><u>Proprietary Architecture</u> Reuse within company Retains IP High Costs Hard to keep up</p>	<p><u>Closed, Purpose Built</u> Exact fit Lower cost if volumes high Longer time to market</p>
<p><u>Open General Purpose</u> Maximum reuse Common components Fast to market Interoperability issues Generally higher cost</p>	<p><u>Open & Focused Architecture for Specific Industry</u> Higher interoperability More reuse Fast to market</p>

Open

General Purpose

AdvancedTCA™

Purpose Built



Telecom is the right focus:

- Market & Technology changes are forcing behavior changes
 - Shift from proprietary to open
- The Telecom market is large enough to support volumes of standard products
 - And most are still proprietary

Telecom is a BIG Market And is still growing

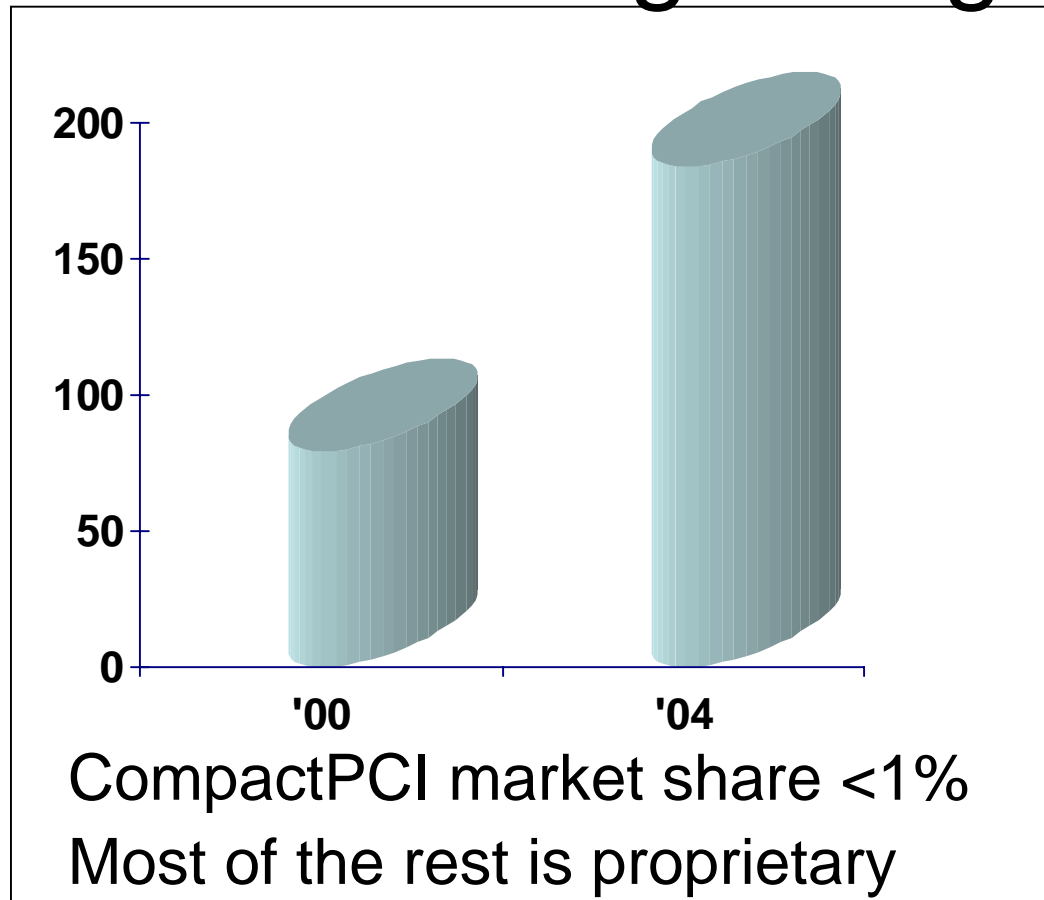

Make the pie bigger.

Now

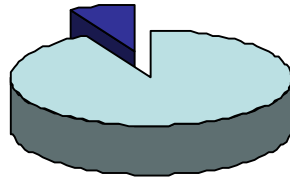

2004

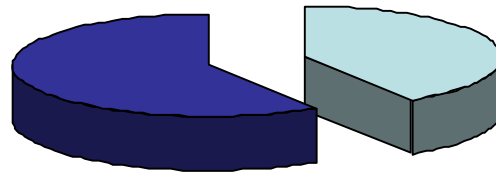

■ Proprietary

■ Standard

AdvancedTCA™



Telecom Focus

- Telecom Focus drives:
 - Interconnect Decisions
 - Form Factor
 - Power Supply
 - Management
 - Reliability
- But it is also demanding!
 - Stringent reliability demands
 - Stringent regulatory requirements
 - Very technical customers

AdvancedTCA™



Is it only Telecom?

- Data Centers have “similar needs”
- Even large enterprise are looking at modular computing.
- And what about?
 - Medical
 - Industrial Automation
 - Military Comms
- Let’s not get distracted

If AdvancedTCA can apply – then it will be used
We must focus on Telecom

AdvancedTCA™



Goals of AdvancedTCA

- Meet the needs of a large segment of the Telecom equipment market for open architecture products
- Gain acceptance by large equipment makers
- Become the standard for next generation equipment
- Do it soon!

AdvancedTCA™



AdvancedTCA Market Space

Chuck Byers

Bell Labs Fellow

Lucent Technologies

AdvancedTCA™



AdvancedTCA Application Focus

- Primary:
 - Telco Carrier Grade applications based on standard fabric solutions
- Secondary:
 - Data Center Modular Servers

AdvancedTCA™



What does the marketplace need from a new platform standard?

- Scalable capacity to 2.5Tb/s
- Scalable system availability to 99.999%
- Multi-protocol support for interfaces up to 40Gb/s
- High levels of modularity and configurability
- The ability to host large pools of DSPs, processors, and storage

AdvancedTCA™



What does the marketplace need from a new platform standard?

- Support for convergence of: access, metro, core, optical, switching, server, storage, voice, data, video, and wireless functions
- Advanced system management infrastructure
- World-class element cost and operational expense
- Open standards
- A healthy, dynamic, multi-vendor, interoperable “ecosystem”
- Available in 2002, with a design-in life through 2009

AdvancedTCA™



Why don't existing standards meet these needs?

- Board areas are too small for emerging applications
- Board spacing is too narrow
- Heat dissipation is totally inadequate for next generation semiconductors
- Backplane capacity is severely limited
- Signal integrity and electromagnetic compatibility are becoming problems
- Mechanical standards don't support I/O requirements

AdvancedTCA™



Why don't existing standards meet these needs?

- Power distribution systems need modernization
- Hardware management is often inadequate
- Existing platforms are often optimized for a limited set of applications, where convergence requires more universal platforms
- Poor scaling of capacity, performance, and reliability
- Cost is too high

AdvancedTCA™



Applications Served by AdvancedTCA

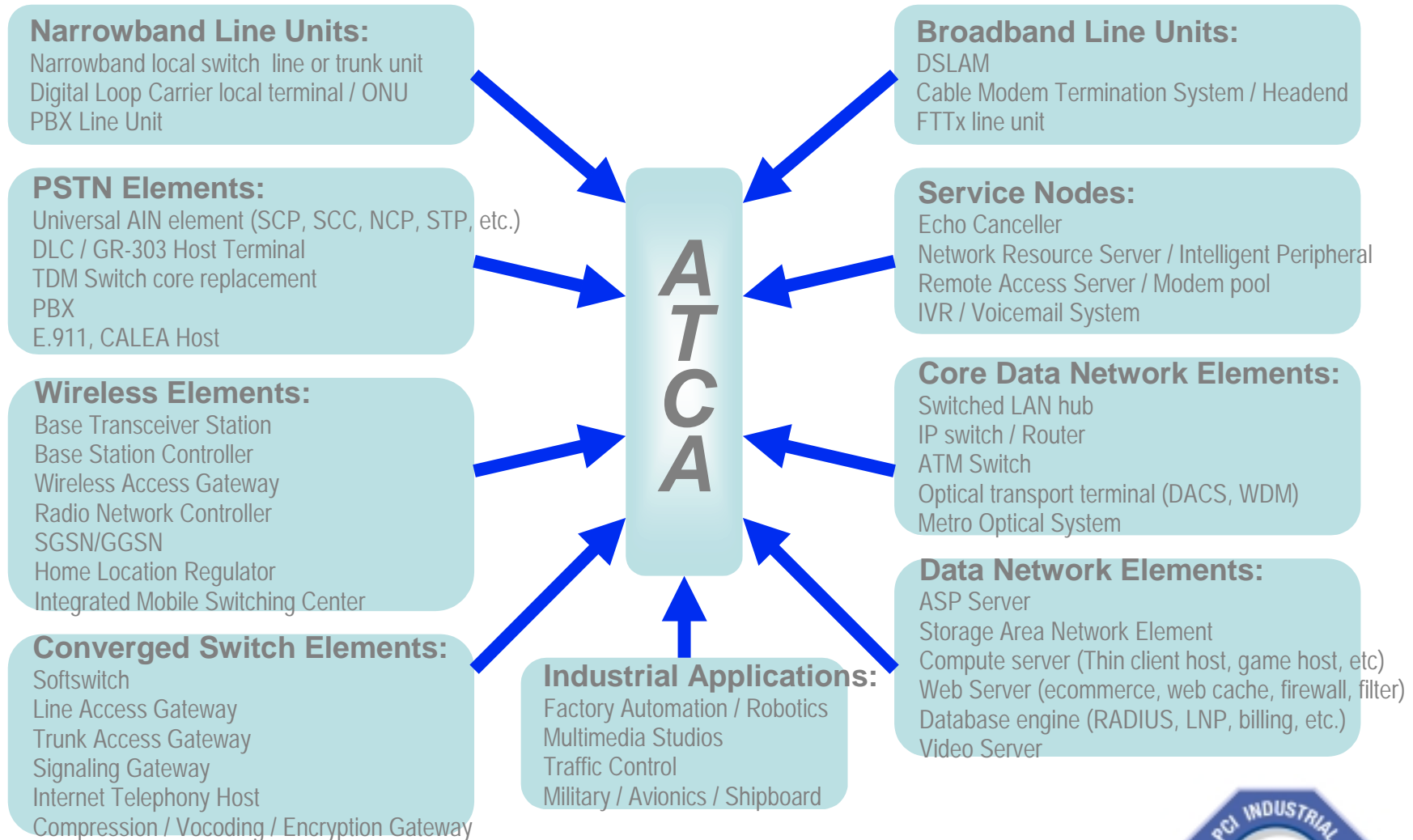

AdvancedTCA™



Platform Technology Comparison

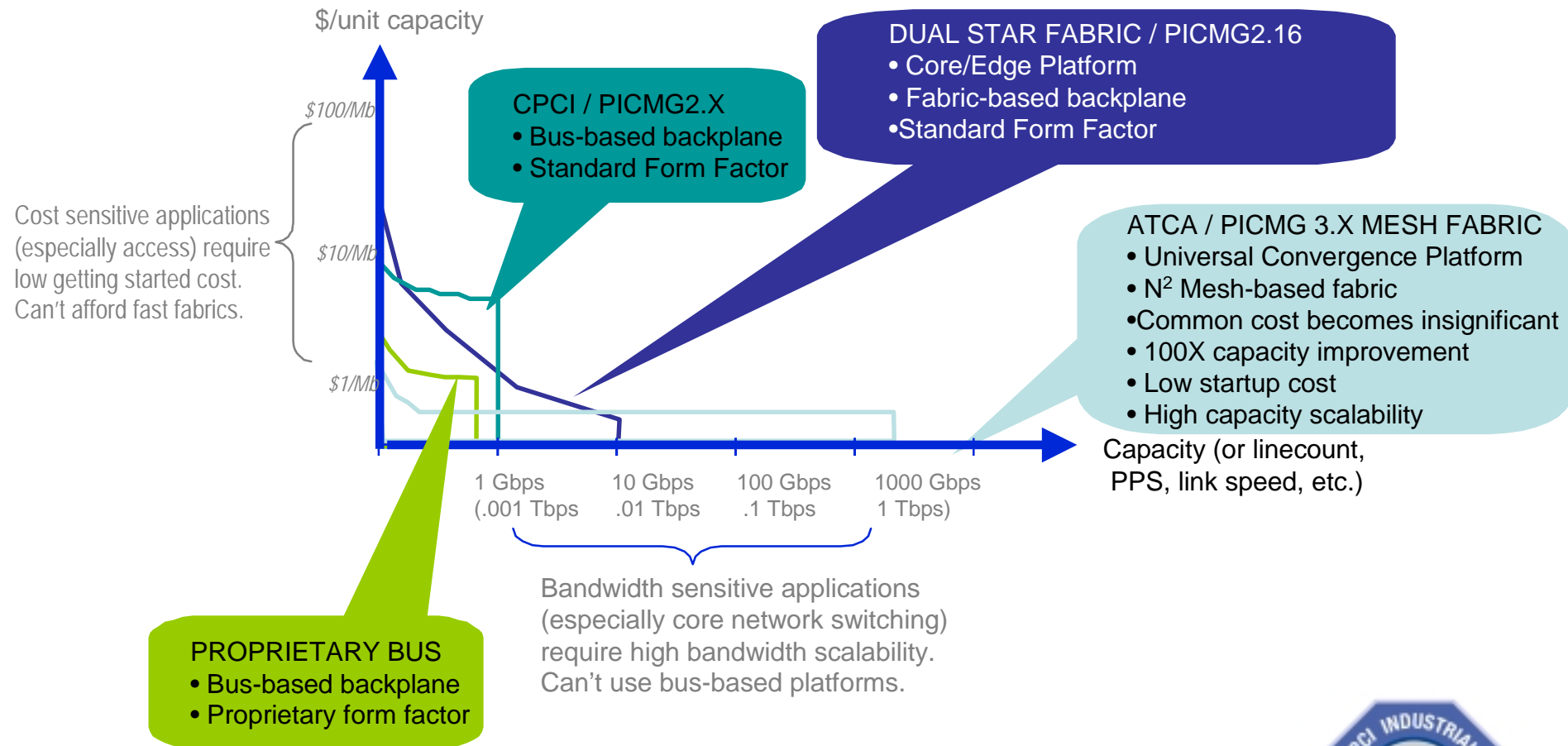

AdvancedTCA™



AdvancedTCA

An Introduction to:

Why?

What?

When?

Whom?

Joe Pavlat

Cypress Point Research & PICMG

AdvancedTCA™



Why?

- More board real estate needed now:
 - Bigger processors and multiple processors on a single board (example: Pentium 4 or SPARC + DSP + Network Processor)
 - Large amounts of memory: 8+ gigabytes not uncommon
 - Heat sinks
 - Optical components like DWDM's
- Larger board pitch (more component height) needed:
 - CPU's with integral heat sinks
 - DIMM memory modules
 - More air volume for better cooling

Why?

- Higher power needed:
 - CompactPCI practically limited to 35-50 watts/board
 - Emerging CPU's take 70+W just for the CPU!
 - 150-200W / board a realistic requirement (>3KW / shelf) in near future
- Different power distribution needed:
 - 3.3V at 1000 amps doesn't make sense
 - Core logic voltages a moving target
 - Practical solution: Distribute a higher voltage at a lower current to each board and regulate locally as required

Why?

- Higher data bandwidth needed:
 - 500 Mbytes/sec (PCI 64 bit - 66MHz) too slow
 - Many new fabrics use 2.5 Gbps LVDS physical layer
 - Gigabytes/Terabytes per second per shelf a practical requirement
- Point-to-point switched fabrics a completely different architecture than parallel buses like VME or PCI – existing architectures inadequate.
- Improving reliability means reducing size of failure domain. A big problem for conventional parallel buses. Serial buses make it easier to isolate failures.

Why?

- Robust System Management a “gotta-have”, not a “nice-to-have”.
- Existing Rear Panel I/O methodologies too inflexible:
 - Need high density I/O
 - Need high frequency I/O
 - Need controlled impedance I/O
 - Need optical I/O
 - Need to mix and match within a shelf

What?

- PICMG 3 spec family – “AdvancedTCA”
- A high performance, high power platform for switched fabric architectures
- Core spec “fabric agnostic”. Designed to accommodate many emerging fabrics
- Something that can be done in less than 1 year. That implies using an existing electromechanical standard (IEC60297 used by VME and CompactPCI)
- Something with a design lifetime of 7-10 years

AdvancedTCA™



What?

- **Bigger Board:**
 - 140 sq. in. for AdvancedTCA at 1.2” pitch
 - 57 sq. in. for 6U CompactPCI and VME at 0.8” pitch
- **Higher Power:**
 - 150-200W per board for AdvancedTCA
 - 35-50W per board for CompactPCI
 - Carefully modeled thermal environment
- **Optimized for Central Office telco applications:**
 - Specific NEBS, ETSI, IEC requirements written into spec.
- **Shelf size optimized for 42U high rack (more later)**

AdvancedTCA™



What?

- Dual -48VDC power distribution to each card
- Copper fabric interconnect (optical signals limited to I/O)
- High speed differential connector for data fabric (after long debate and analysis, Tyco/ERNI HM ZD family chosen)
- Uniform System Management architecture independent of fabric technology
- Flexible Rear I/O methodology:
 - RTM's plug directly onto front cards. Permits wide range of connectors to be used.

AdvancedTCA™



What?

- Structured family of specifications
- Core 3.0 spec defines
 - Equipment practice, mechanicals
 - Connectors
 - System Management architecture
 - Rear I/O techniques
 - Regulatory requirements
- Follow-on specs add individual fabrics:
 - 3.1 for switched Ethernet
 - 3.2 for InfiniBand
 - 3.3 for StarFabric
 - More as members desire to develop

When?

- Core spec draft Q2 2002 (goal)
- Core spec ratification Q3 2002 (goal)
- Some fabrics (esp. 3.1 and 3.2) in parallel
- PlugFest September 2002

How Does This Affect the CompactPCI Market?

- As the analysts have shown us, CompactPCI will continue to grow
- Still the right solution for a large class of applications
- AdvancedTCA aimed at a completely different market:
 - Central Office Telecom w. –48VDC power distribution
 - Very high end, Very high performance
 - “Central Office in a Box”
 - Dozens of CPU’s per chassis
 - Integral High Performance Switch Fabric
 - Applications not now served by CompactPCI
- AdvancedTCA will not have much effect on existing CompactPCI space

AdvancedTCA™



Modular Building Block Evolution

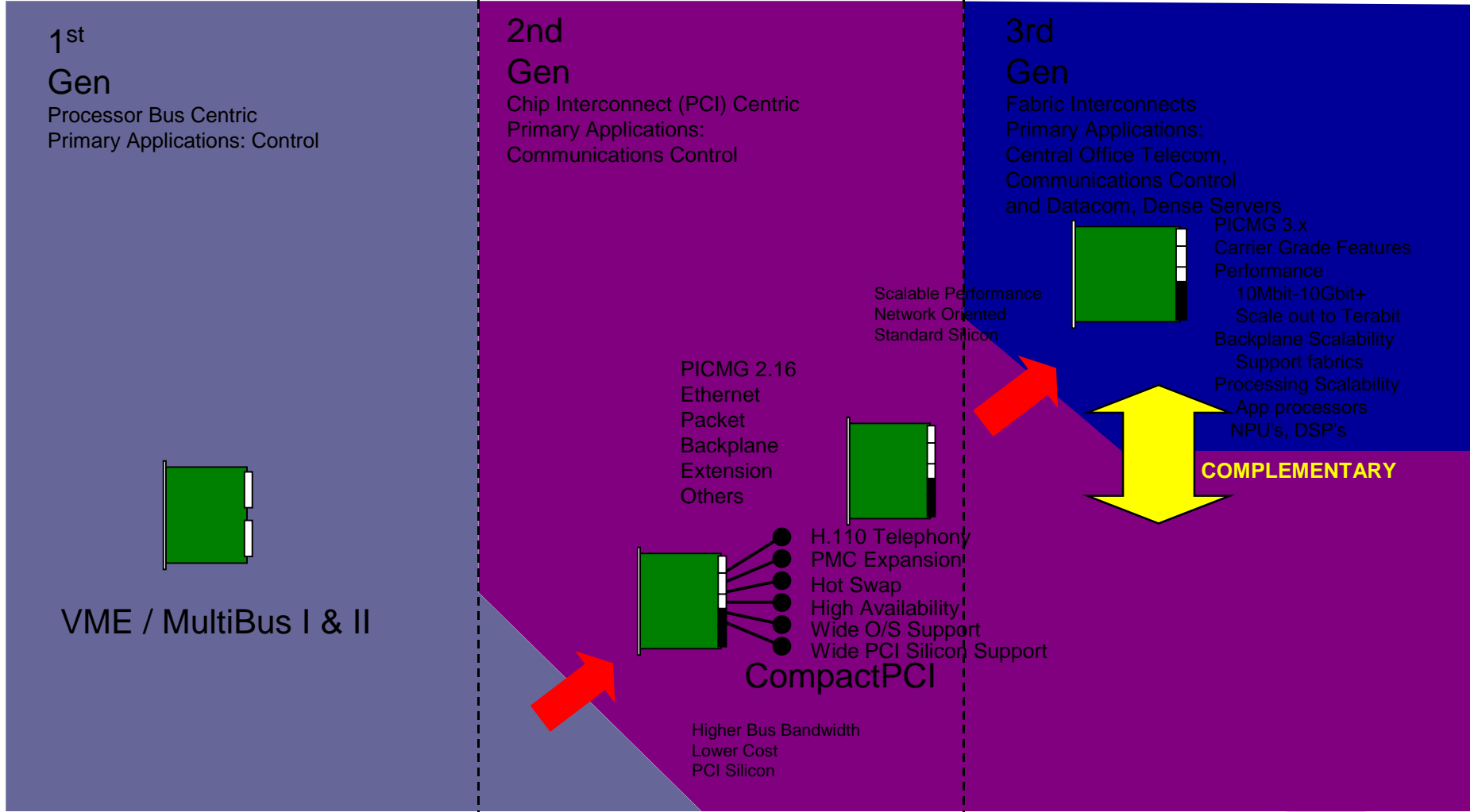

1980 1990 1994 2000 2002/3

AdvancedTCA™

AdvancedTCA™



Whom?

- Big Effort! 95 participating member companies!
- 3.0 Subcommittee:
 - Chair: [Jeff Munch](#), Director of Engineering, Motorola Computer Group
 - Vice-Chair [Jim Medeiros](#), Communications Platform Director, Intel ICG CTO Office
 - Editor: [Dick Somes](#), Standards Director, Force Computers
 - Secretary: [Ron Smith](#), Intel
- Sub-teams:
 - Form Factor: [Joe Pavlat](#), Cypress Point Research
 - Data Fabric: [Jim Kennedy](#), Intel
 - System Management: [Jack Brindle](#), SUN



Whom?

- 3.1 Switched Ethernet Subcommittee:
 - John Peters, Performance Technologies
- 3.2 InfiniBand Subcommittee:
 - Chuck Byers, Lucent Technologies
 - Chris Eddington, Mellanox
- 3.3 StarFabric Subcommittee:
 - Steve Christo, StarGen

PICMG 3 Architecture

- Features
- Issues
- Schedule



PICMG 3 Architecture

- Mechanical/Thermal
- Power Distribution
- Data Transport
- Platform Management
- Reference Platform

AdvancedTCA™



PICMG 3 Mechanicals

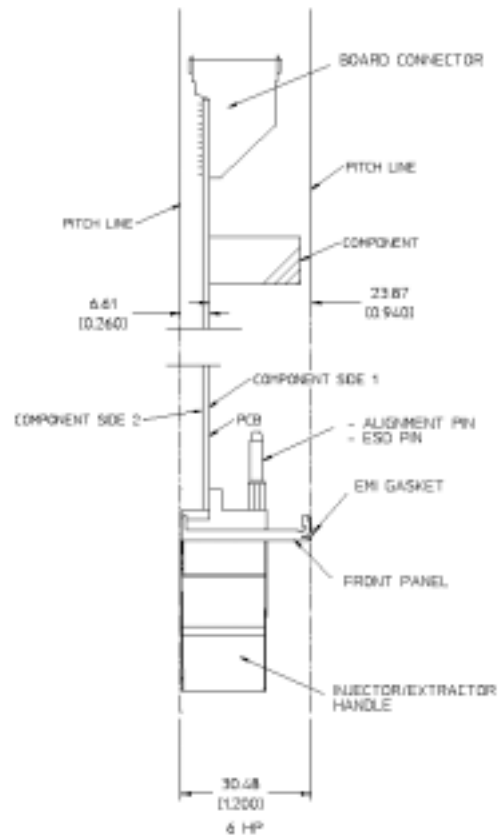

PICMG 3 Mechanicals

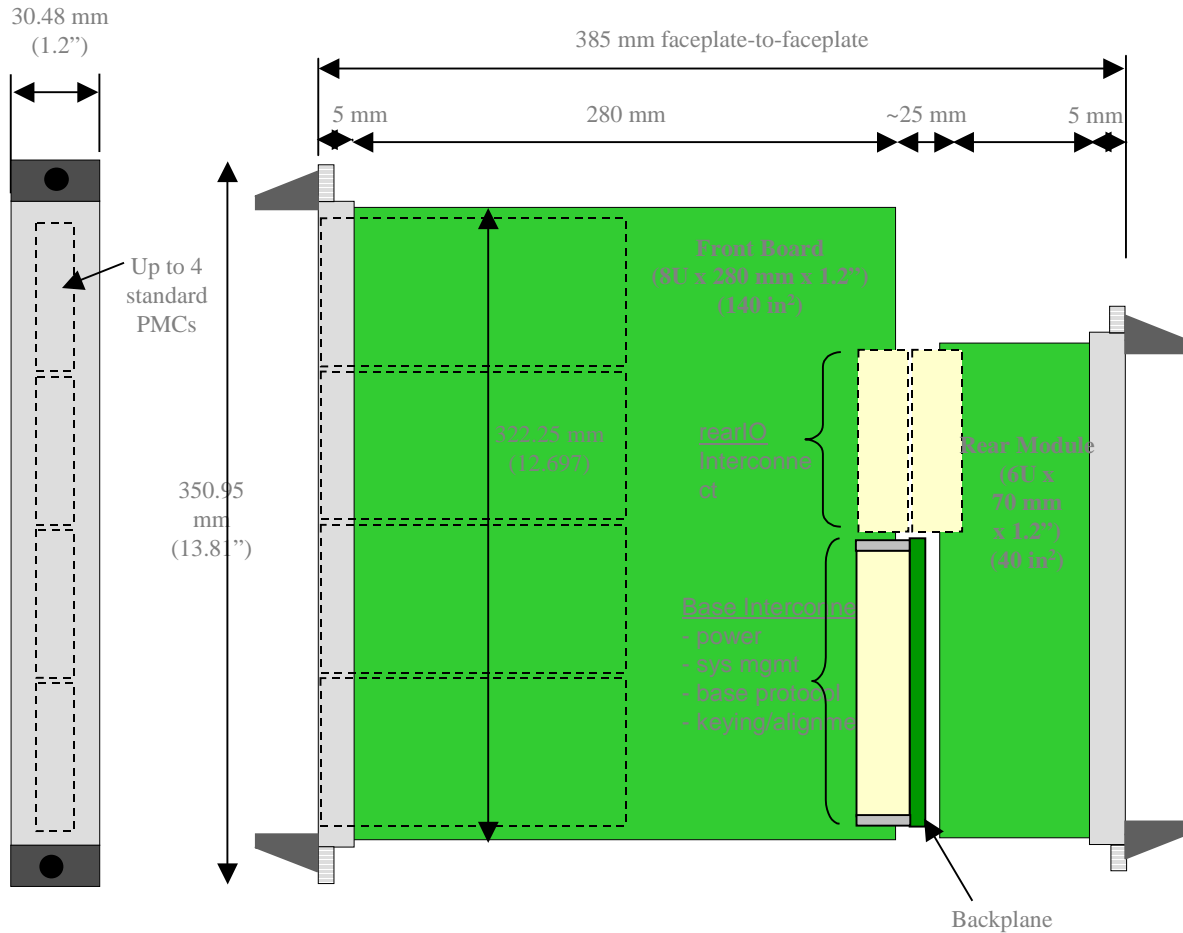

AdvancedTCA™



2mm Differential “ZD” Connector

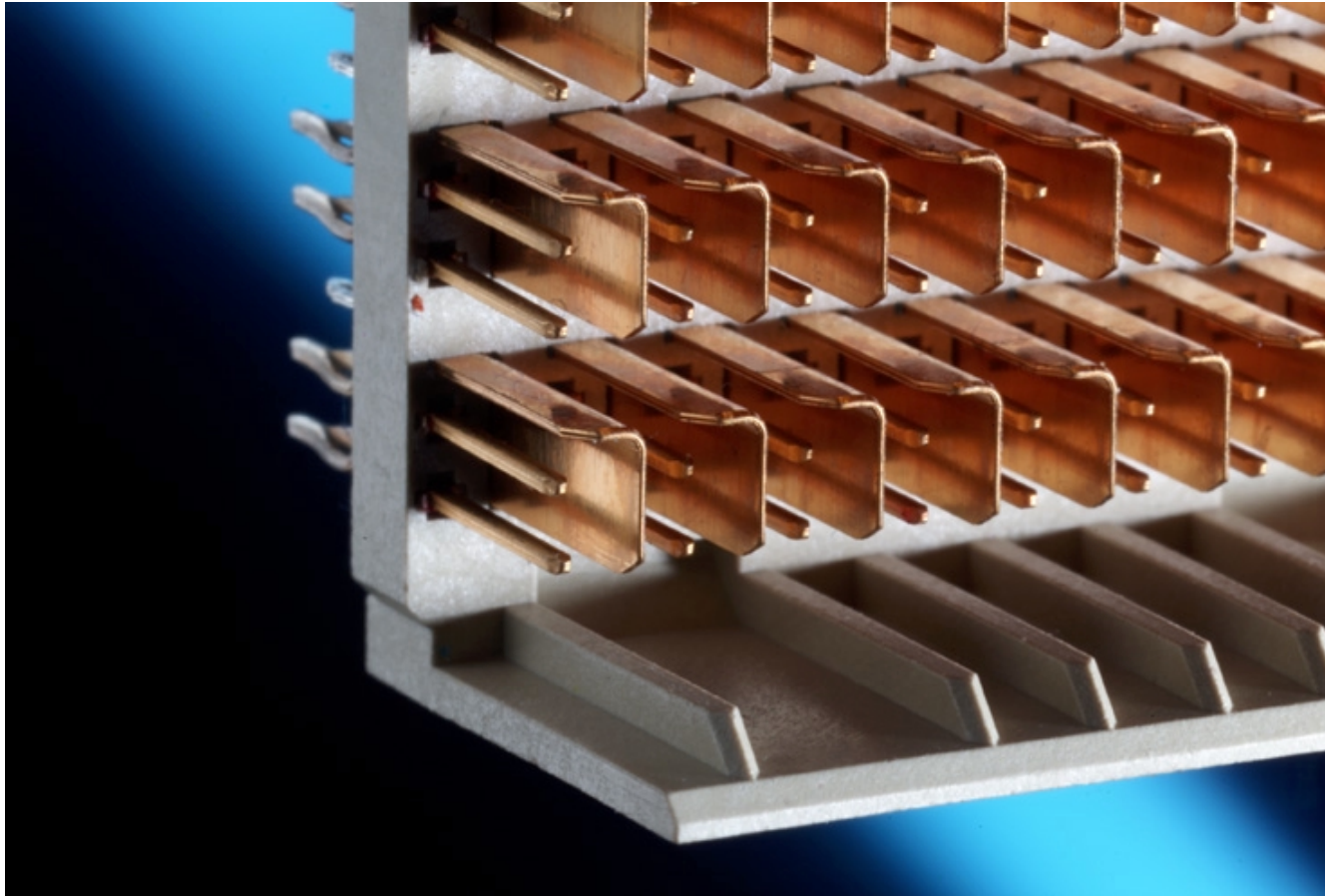

AdvancedTCA™



PICMG 3 Thermal Concept

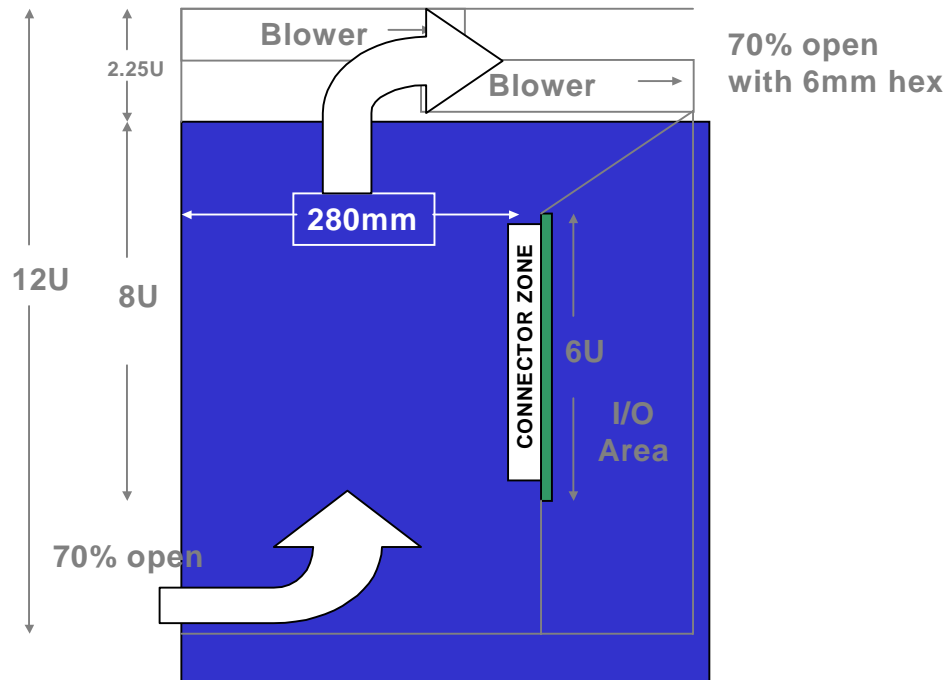

Thermal Sampler

Flow Scenarios

Temperature plane

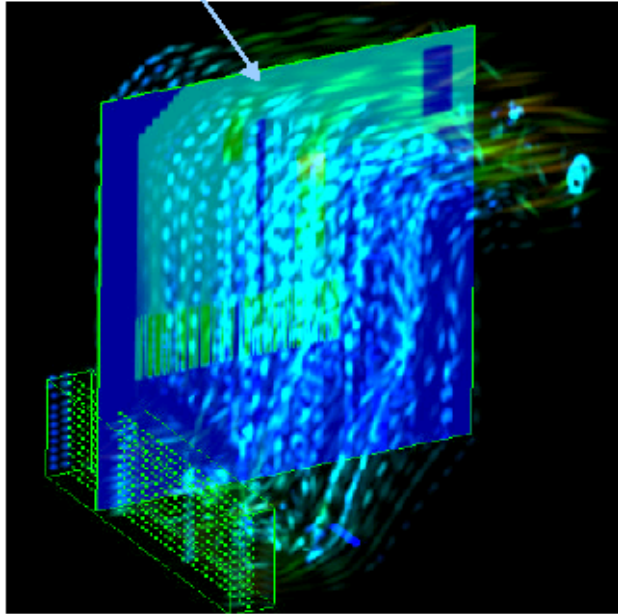

All fans operating - typical
(Slot 4)

Temperature plane

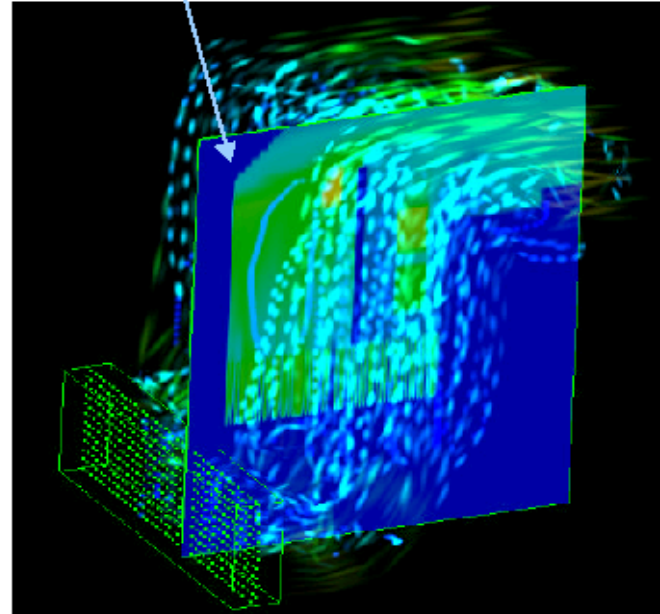

fan #2 fail
(Slot 9)

8Ux280 Checkpoint #2, Nov 7, 2001 Motorola Computer Group

AdvancedTCA™



Stars and Meshes

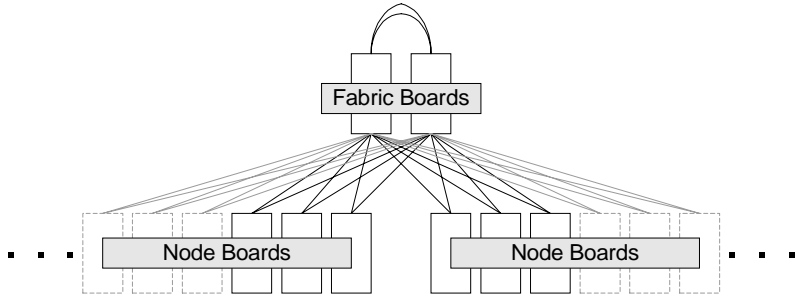

Star Topology

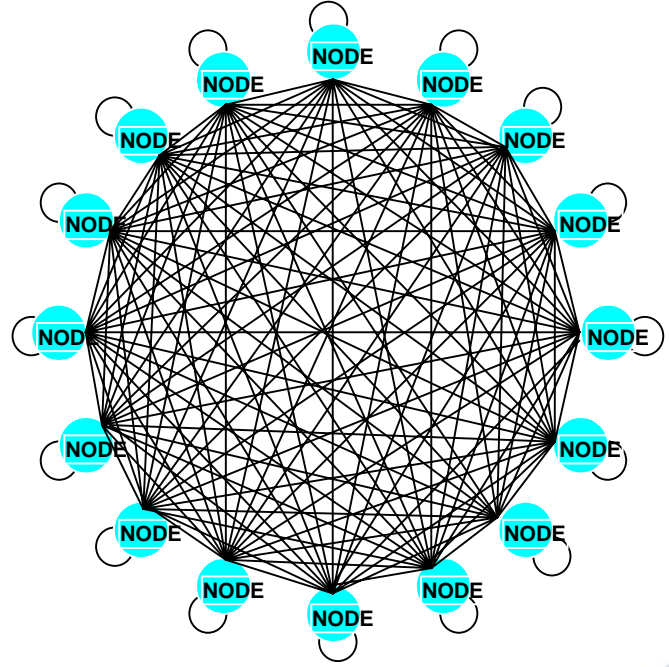

Mesh Topology

Full Mesh Backplane - 16 slots

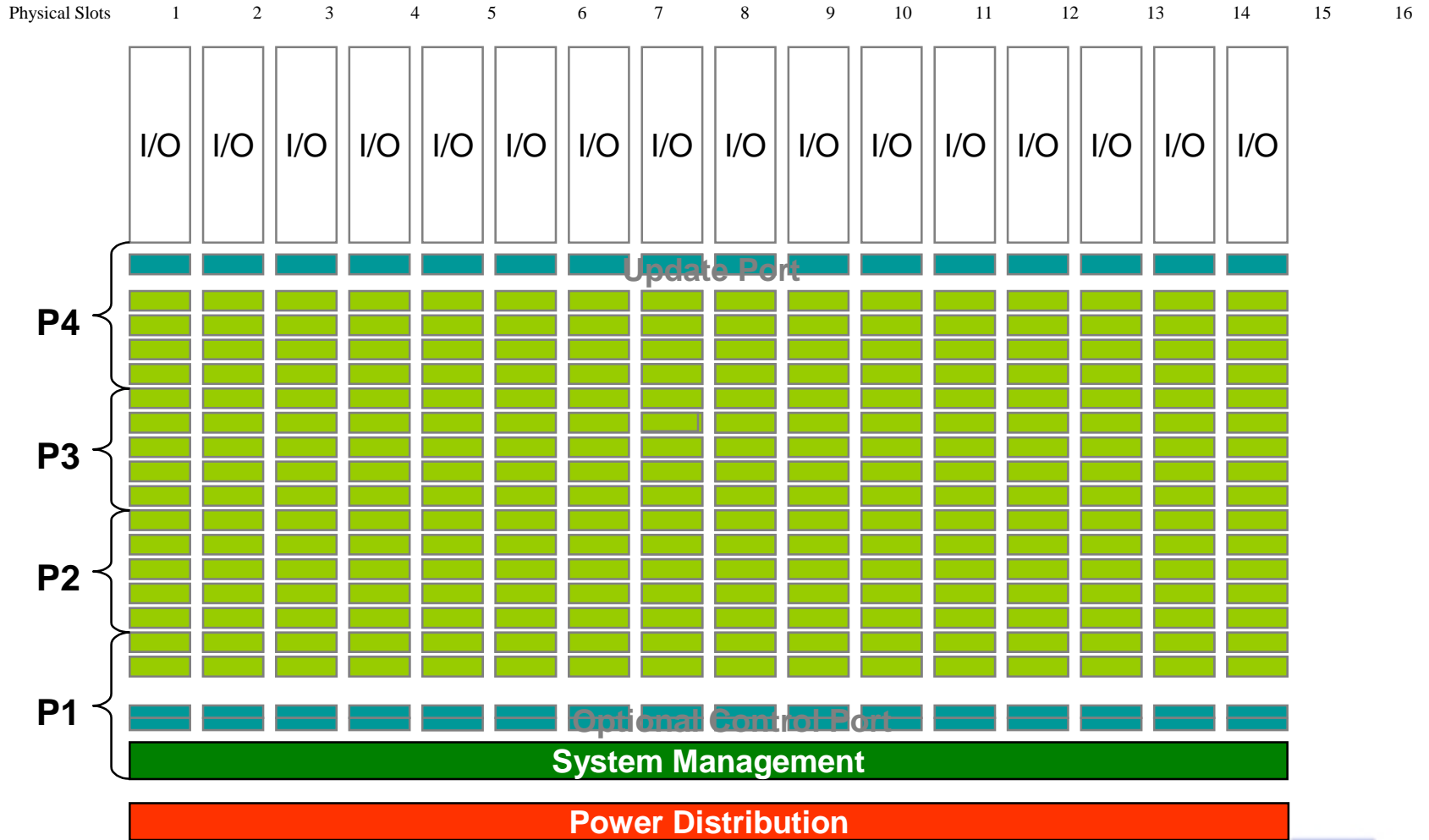

AdvancedTCA™



Full Mesh – Square Mesh Detail (Mesh Only Detail – excludes system management/update bus)

Physical Slots:	1	2	3	4	5	6	7	8	9	10	11	12	13	14	15	16
Logical Slots:	1	2	3	4	5	6	7	8	9	10	11	12	13	14	15	16
1-16	2-16	3-16	4-16	5-16	6-16	7-16	8-16	9-16	10-16	11-16	12-16	13-16	14-16	15-16	16-16	
1-15	2-15	3-15	4-15	5-15	6-15	7-15	8-15	9-15	10-15	11-15	12-15	13-15	14-15	15-15	16-15	
1-14	2-14	3-14	4-14	5-14	6-14	7-14	8-14	9-14	10-14	11-14	12-14	13-14	14-14	15-14	16-14	
1-13	2-13	3-13	4-13	5-13	6-13	7-13	8-13	9-13	10-13	11-13	12-13	13-13	14-13	15-13	16-13	
1-12	2-12	3-12	4-12	5-12	6-12	7-12	8-12	9-12	10-12	11-12	12-12	13-12	14-12	15-12	16-12	
1-11	2-11	3-11	4-11	5-11	6-11	7-11	8-11	9-11	10-11	11-11	12-11	13-11	14-11	15-11	16-11	
1-10	2-10	3-10	4-10	5-10	6-10	7-10	8-10	9-10	10-10	11-10	12-10	13-10	14-10	15-10	16-10	
1-9	2-9	3-9	4-9	5-9	6-9	7-9	8-9	9-9	10-9	11-9	12-9	13-9	14-9	15-9	16-9	
1-8	2-8	3-8	4-8	5-8	6-8	7-8	8-8	9-8	10-8	11-8	12-8	13-8	14-8	15-8	16-8	
1-7	2-7	3-7	4-7	5-7	6-7	7-7	8-7	9-7	10-7	11-7	12-7	13-7	14-7	15-7	16-7	
1-6	2-6	3-6	4-6	5-6	6-6	7-6	8-6	9-6	10-6	11-6	12-6	13-6	14-6	15-6	16-6	
1-5	2-5	3-5	4-5	5-5	6-5	7-5	8-5	9-5	10-5	11-5	12-5	13-5	14-5	15-5	16-5	
1-4	2-4	3-4	4-4	5-4	6-4	7-4	8-4	9-4	10-4	11-4	12-4	13-4	14-4	15-4	16-4	
1-3	2-3	3-3	4-3	5-3	6-3	7-3	8-3	9-3	10-3	11-3	12-3	13-3	14-3	15-3	16-3	
1-2	2-2	3-2	4-2	5-2	6-2	7-2	8-2	9-2	10-2	11-2	12-2	13-2	14-2	15-2	16-2	
1-1	2-1	3-1	4-1	5-1	6-1	7-1	8-1	9-1	10-1	11-1	12-1	13-1	14-1	15-1	16-1	

Square Mesh
 Full Mesh Capability between all slots
 Defined mapping of signals for consistent node connectivity
 Physical slots may differ from the logical slot.
 (Every node slot '-1' connection is defined)

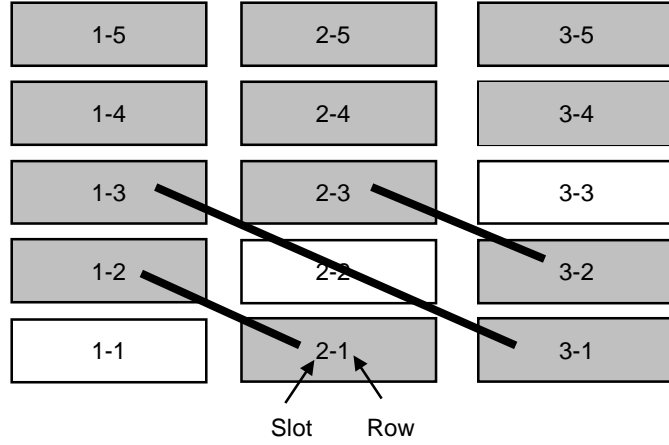

AdvancedTCA™



Frame Level Power Distribution

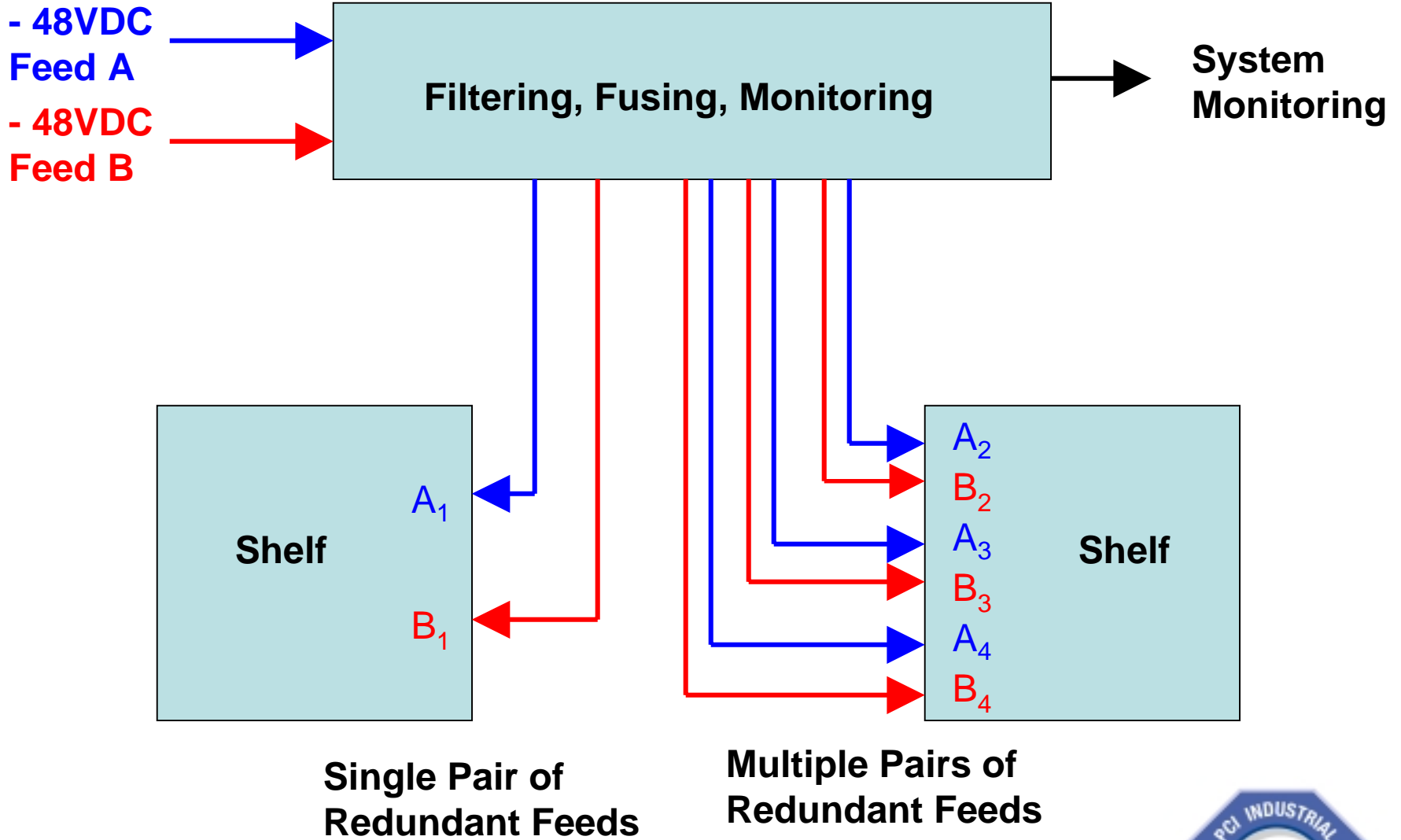

Diode OR'ing of Feeds to Single DC-DC Converter per Card

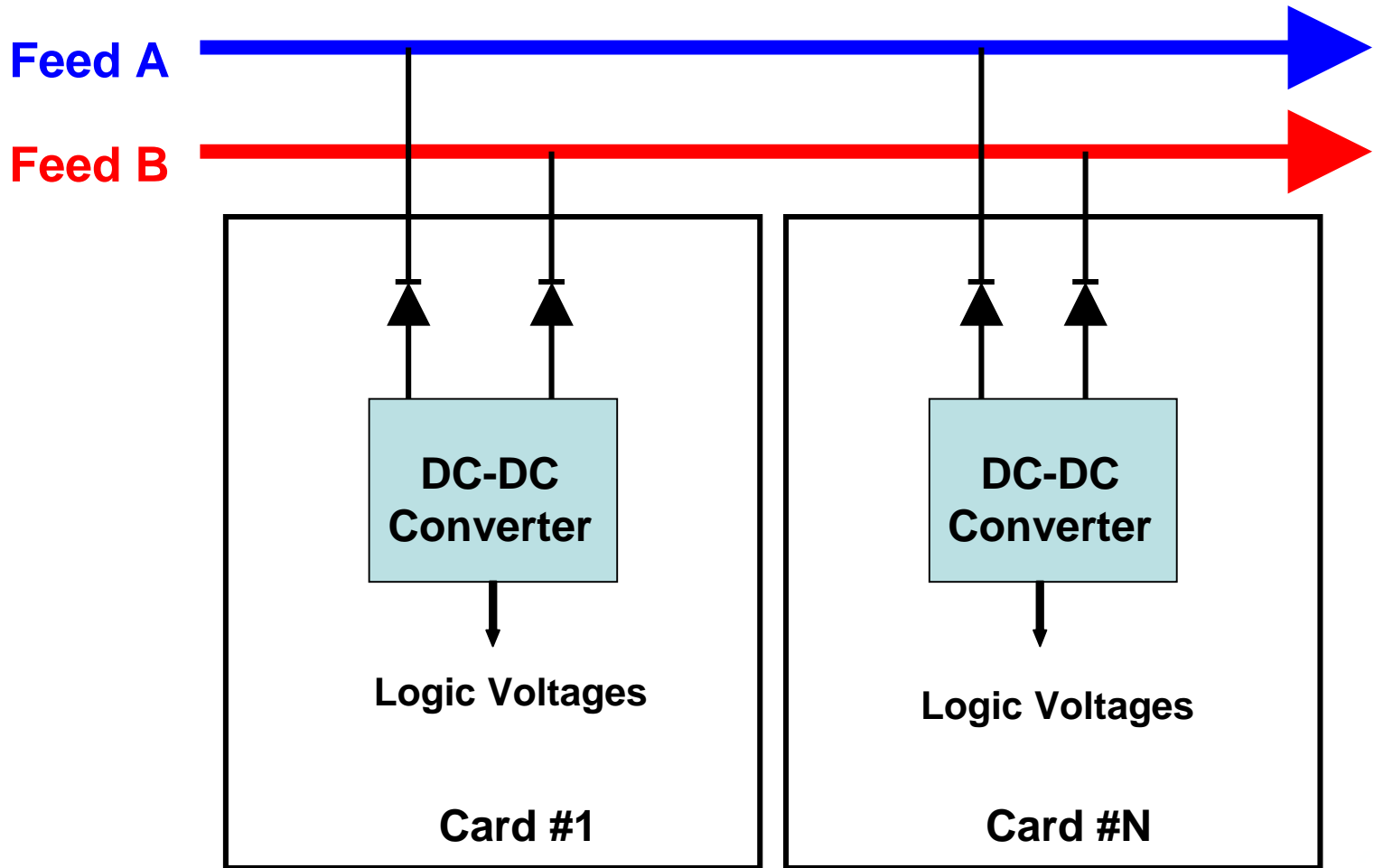

Redundant, Load Sharing DC-DC Converters

Feed A

Feed B

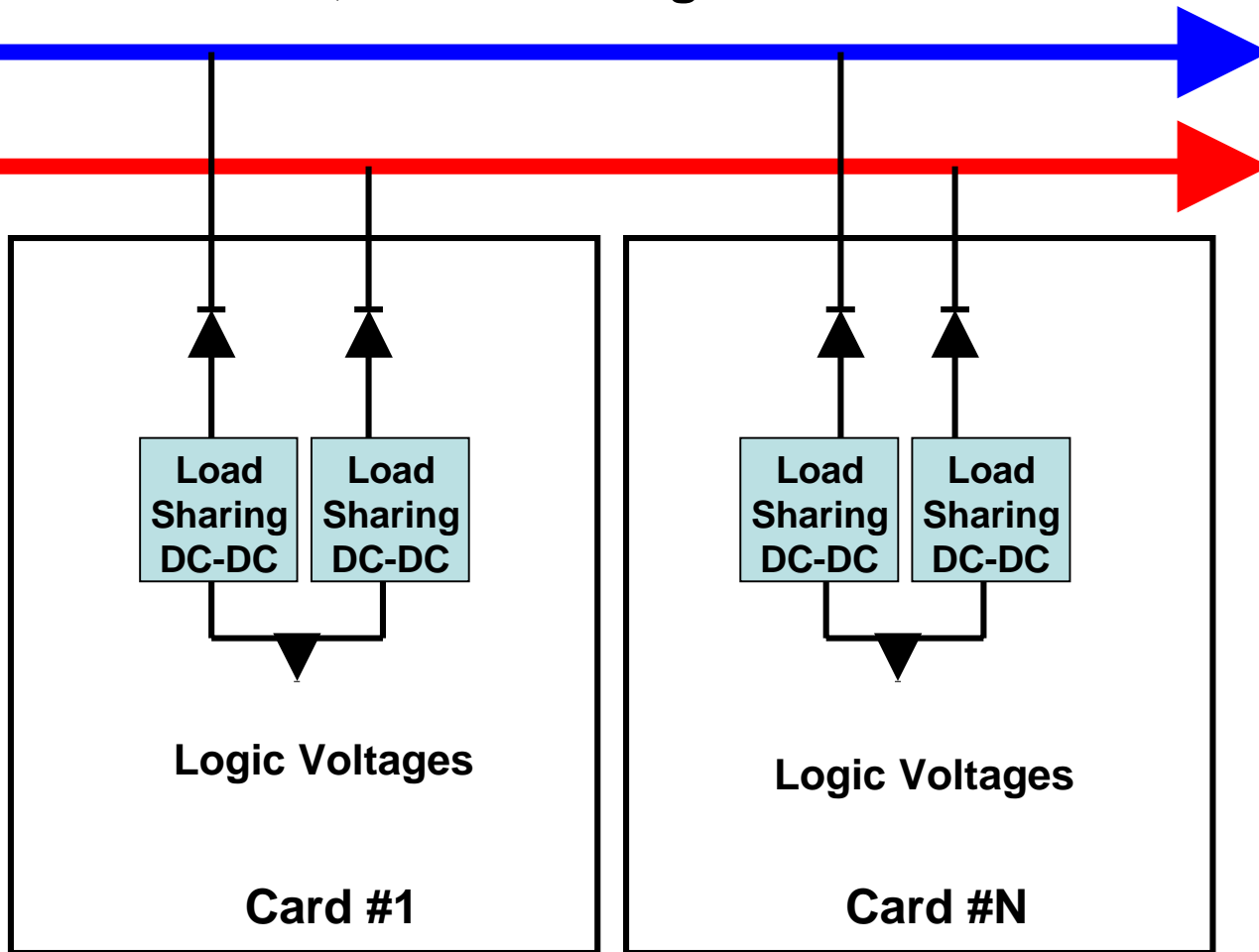

AdvancedTCA Mesh Node Board Reference Design

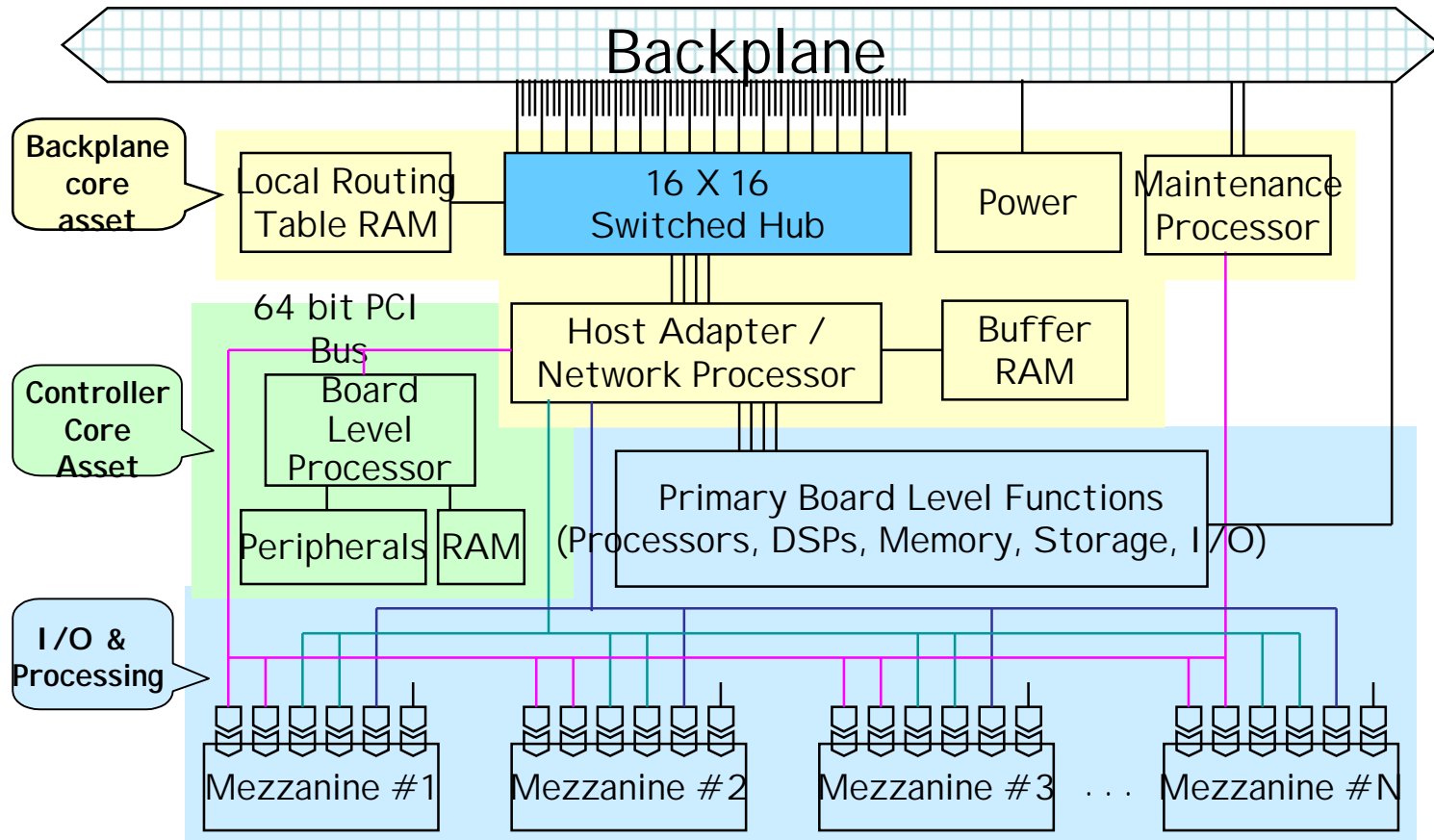

Platform Management

- IPMI v1.5 compliant management controllers
 - Leverages PICMG 2.9
- I²C interconnect for HWM
- Interface with IP based management infrastructure
 - SNMP
 - bootp
 - RMCP

PICMG 3 Issues

- Board Form Factor
 - Resolved: 8U x 280 mm
- Connector
 - Resolved: Tyco/ERNI Ermet/HM ZD
- Dedicated control/management port
 - Resolution imminent
- Power connector
 - Requirements definition

PICMG 3 Schedule

- Kickoff
 - November 13-14 2001
- Resolution of major issues
 - January 2002
- Subcommittee Review
 - Face to face meetings in March and May 2002
- Final Subcommittee Ballot
 - May/June 2002
- Adoption
 - September 2002

